

COMPACT GI FANS

WITH RUGGED RADIAL-BLADE WHEELS

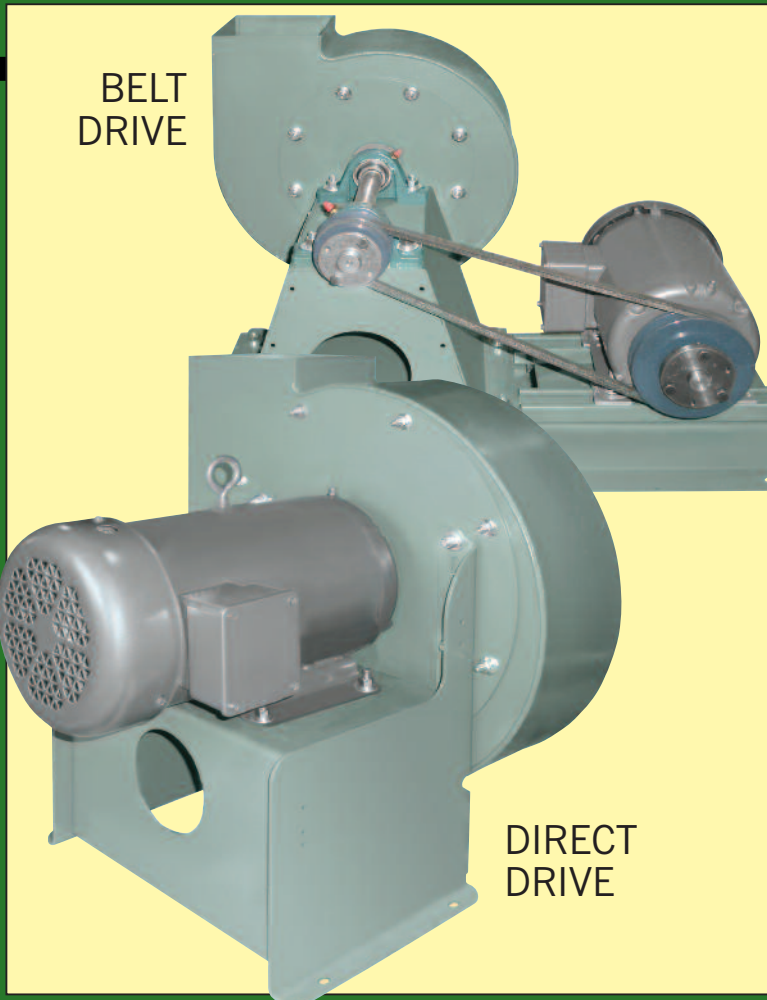

- Capacities to 2,200 CFM
- Static pressures to 14"WG
- Temperatures to 600°F.



SERIES 20 GI FANS

- Capacities to 77,000 CFM
- Static pressures to 22"WG



SERIES 30 GI FANS

- Capacities to 95,000 CFM
- Static pressures to 32"WG



SERIES 45 GI FANS

- Capacities to 100,000 CFM
- Static pressures to 46"WG



THE NEW YORK BLOWER COMPANY
7660 Quincy Street
Willowbrook, IL 60527-5530

Visit us on the Web: <http://www.nyb.com>
Phone: (800) 208-7918 Email: nyb@nyb.com

COMPACT GI FANS

...for industrial air-handling processes

Compact GI Fans, sometimes referred to as pressure blowers, are ruggedly constructed for a wide variety of industrial air-handling processes.

TYPICAL APPLICATIONS

- Dust collection
- Grinding-booth exhaust
- Scrubber exhaust
- Food and drying ovens
- Sawdust and wood-chip conveying
- Paper-trim systems

This bulletin covers only Compact GI Fans, the lower capacity element of four **nyb** radial-blade fan lines which cover a wide range of performance and application requirements. The design parameters and standard features of the Compact GI Fan are listed below.

- 8" through 14" wheel diameters provide capacities to 2200 CFM and 14"SP.
- Temperatures to 600°F.
- Heavy-gauge welded steel housing and pedestal provide structural strength and durability.
- Lubricatable self-aligning ball bearings with cast-iron housings provide extended service life over full catalog range.

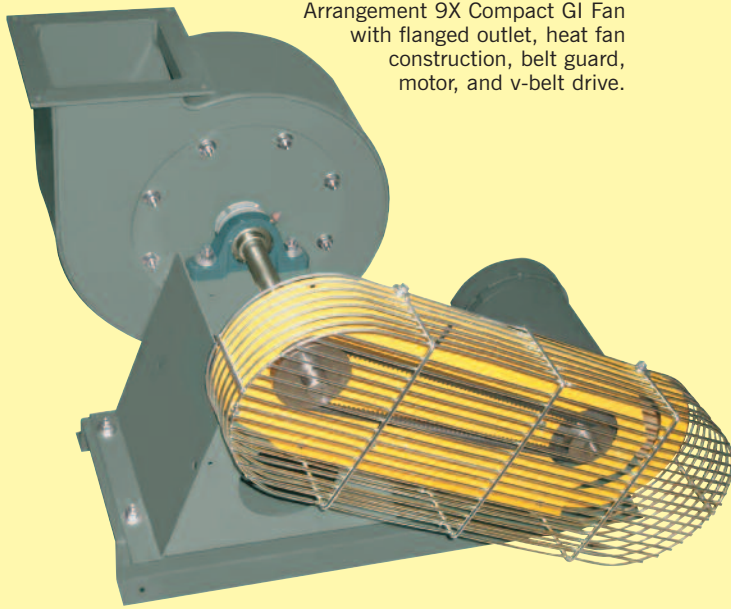

Arrangement 9X Compact GI Fan with flanged outlet, heat fan construction, belt guard, motor, and v-belt drive.



Arrangement 4V Compact GI Fan with motor.



AMCA SEAL

The New York Blower Company certifies that the Compact GI Fans shown herein are licensed to bear the AMCA Seal. The ratings shown are based on tests and procedures performed in accordance with AMCA Publication 211 and comply with the requirements of the AMCA Certified Ratings Program.



CAST RADIAL-BLADE WHEEL

ALUMINUM

- 200°F. maximum temperature
- Spark-resistant
- Corrosion-resistant
- Clean-air applications
- Low cost

NICKEL-ALUMINUM BRONZE [NAB]

- 600°F. maximum temperature
- Spark-resistant
- Corrosion-resistant
- Abrasion-resistant
- Material-handling

- Fan housing and pedestal are finished with a green polyester powder coating.
- Most sizes are rotatable to any of seven standard discharges in the field.
- Compact GI Fans offer stable pulsation-free performance from wide-open to closed-off.

ARRANGEMENTS

ARRANGEMENT

1

BELT DRIVE



V-belt drive configuration allows selection of any of six fan sizes at a variety of fan speeds. Provides flexibility in performance simply by adjusting or changing drive sheaves. Maximum temperatures: 200°F.-aluminum wheel; 300°F.-NAB wheel; 600°F.-heat fan.

MOTOR-POSITION DESIGNATION

Drawing at right shows AMCA motor-position designations. This designation must be given when ordering Arrangement 1 fans with V-belt drives and/or belt guard. Motor positions are independent of rotation and discharge and are determined by viewing fan shaft from drive end.

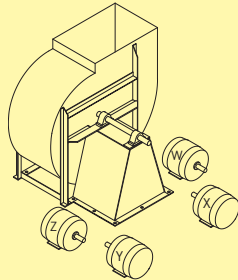

ARRANGEMENT

9

BELT DRIVE

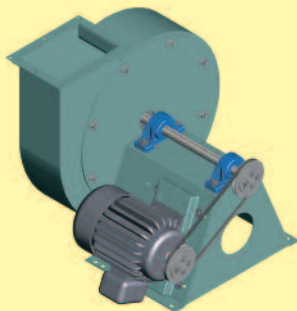

Compact V-belt drive configuration integrates motor and drive with fan in one assembly. Package allows factory assembly and testing, and minimizes costly field labor. Available in six sizes. Maximum temperatures: 200°F.-aluminum wheel; 300°F.-NAB wheel. See page 11 for maximum motor sizes.

ARRANGEMENT

9X

BELT DRIVE

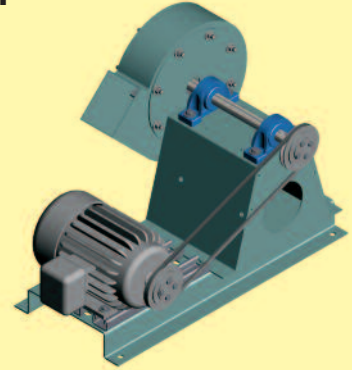

Used when motor is too large for Arrangement 9 or when a higher temperature package is desired. Maximum temperatures: 200°F.-aluminum wheel; 300°F.-NAB wheel; 600°F.-heat fan. See page 11 for maximum motor sizes.

ARRANGEMENT

4

DIRECT DRIVE

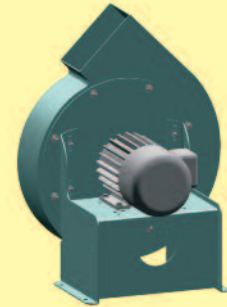

Direct-drive configuration available in nine sizes at 3500 RPM and 1750 RPM, provides simplest, most economical package. Fan wheel is mounted on motor shaft. Not recommended for heavy material-handling applications as material impact may damage motor. Maximum temperature-180°F.

ARRANGEMENT

4V

DIRECT DRIVE

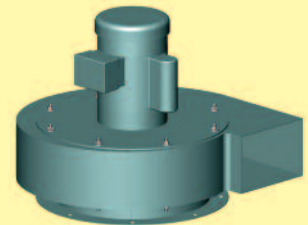

Similar to Arrangement 4, but designed for vertical mounting on fan inlet. Motor is mounted to the drive-side plate, and the inlet plate is reinforced for mounting direct to the process. Maximum temperature-120°F.

ACCESSORIES

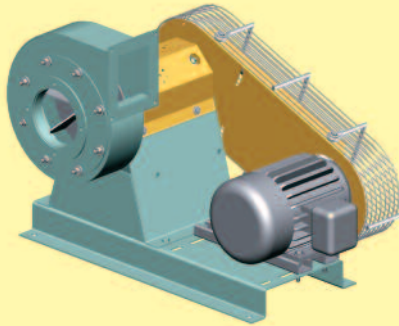

Arrangement 9X Compact GI Fan with flanged inlet, flanged outlet, belt guard, shaft & bearing guard, motor, and v-belt drive components.

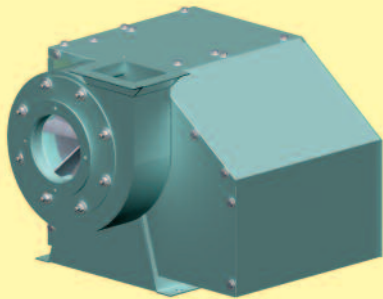

Arrangement 9 Compact GI Fan with flanged inlet, flanged outlet, and weather cover.

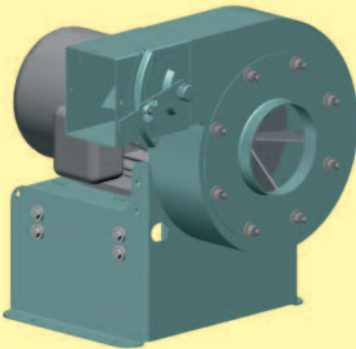

Arrangement 4 Compact GI Fan with motor and slip-type outlet damper.

- **FLANGED INLET**

Flange ring with holes is welded flush to the outer edge of the inlet collar. See page 9 for inlet flange dimensions.

- **INLET FILTER**

Filters are available with a choice of three element types: Wire mesh, hi-flow polyester, and ultra-synthetic. High-efficiency filter is flange mounted, and is furnished with a protective hood. Outboard end of filter should be supported independently of fan.

- **FLANGED OUTLET**

Flange is welded flush with fan outlet and provided with holes. See page 9 for outlet flange dimensions.

- **OUTLET DAMPER**

Single-vane damper slips over fan outlet for all discharges except Down Blast. Also available with flanges for mounting to fan flange and ductwork.

- **WEATHER COVER**

Available for Arrangement 9 and Arrangement 4 fans.

- **TEFLON SHAFT HOLE CLOSURE**

Attached inside housing at the shaft hole opening. Not available for Arrangement 4V fans, or with heat fan or spark-resistant construction.

- **CERAMIC-FELT SHAFT SEAL**

Ceramic-felt seal elements compressed between housing drive-side plate and retaining disc...elements can be split for field replacement. Not available with heat-fan construction or Arrangement 4 or 4V fans.

- **DRAIN**

A $\frac{3}{8}$ " close pipe nipple located at the lowest point in the housing scroll.

- **VIBRATION ISOLATION**

Rubber-in-shear isolators...minimize the transmission of vibration and noise to surrounding structures from Arrangement 4, 9, and 9X fans.

- **SCREENED OUTLET RAINHOOD**

For Arrangement 4V fans, slips over fan outlet to protect fan airstream from the weather.

- **SAFETY GUARDS**

Arrangement 9 and 9X fans can be equipped with belt guards, and shaft and bearing guards. Belt guards for Arrangement 1 fans are available on application.

- **OTHER ACCESSORIES**

Also available from **nyb** are inlet screens, outlet guards, motors, and v-belt drive components.

SAFETY EQUIPMENT

Safety accessories are available from **nyb**, but selection of the appropriate devices is the responsibility of the system-designer who is familiar with the particular installation, or application, and can provide for guards for all exposed moving parts as well as protection from access to high-velocity airstreams. Neither **nyb** nor its sales representatives is in a position to make such determination. Users and/or installers should read "Recommended Safety Practices for Air Moving Devices" as published by the Air Movement and Control Association International, Arlington Heights, Illinois.

MODIFICATIONS

• SPARK-RESISTANT CONSTRUCTION

Three types of spark-resistant construction are available. See separate **nyb** Engineering Letter and consult **nyb** sales representative.

• HANDLING CORROSIVES

Protective coating and special alloys are available to combat corrosion problems.

Thin film coatings [5 to 10 mil thickness]—special paints and spray coatings are available under a variety of trade names. **nyb** works with experienced coating applicators who can apply coatings to meet a wide range of requirements.

Alternate material construction—Compact GI Fans can be constructed of aluminum or various stainless steels.

How to Use PERFORMANCE TABLES

DIRECT DRIVE

The curves and capacity tables on pages 6 and 7 provide CFM, static pressure, BHP, and outlet velocity information for direct-drive Compact GI Fans [see page 10 for maximum motor frame sizes].

BELT DRIVE

The capacity tables on pages 8 and 9 provide CFM, static pressure, BHP, and outlet velocity information for belt-drive Compact GI Fans. The dimension tables on page 11 provide V-belt drive center-distance information and maximum motor frames allowable.

All performance data is based on standard air at .075 lb./cu. ft. density [70°F. at sea level]. If selections are to be based on other temperatures or altitudes, static pressure and brake horsepower must be corrected using the factors shown in Charts II and III. If temperature is a factor, speed must be checked against the safe operating speed in Chart I. Note: Arrangement 4 fans are not suitable for temperatures over 180°F., and Arrangement 4V fans are not suitable for temperatures over 120°F.

EXAMPLE

Select a Compact GI Fan with NAB wheel for 609 CFM at 3000 FPM OV at 2"SP at 325°F. at sea level.

- Chart II shows a 1.48 correction factor for 325°F.
- 2"SP x 1.48 = 2.96"SP at 70°F. [round to 3"SP].
- A Size 106 Compact GI Fan belt drive at 2889 RPM will deliver 609 CFM and 3000 FPM outlet velocity at 3"SP, using .75 BHP.
- To determine static pressure and brake horsepower at conditions, divide the values in Step 3 by the correction factor identified in Step 1:
 $3"SP \text{ at } 70^\circ F. \div 1.48 = 2"SP \text{ at } 325^\circ F.$
 $.75 \text{ BHP at } 70^\circ F. \div 1.48 = .51 \text{ BHP at } 325^\circ F.$
- Actual performance of the Size 106 Compact GI Fan:
 609 CFM at 3000 OV at 2"SP at 2889 RPM at .51 BHP at 325°F.
- Check the safe operating speed of a Size 106 Compact GI Fan with NAB wheel at 325°F. Chart I shows a 4600 RPM safe speed at 325°F. which is greater than the 2889 RPM operating speed.

The method of correcting for altitude is the same as for temperature using the correction factors from Chart III.

HEAT-FAN CONSTRUCTION

Arrangement 1 and 9X Compact GI Fans with NAB wheels can be equipped with shaft coolers which make them suitable for airstream temperatures to 600°F., provided that ambient air temperature at the bearings does not exceed 120°F. The maximum allowable fan speed decreases as the airstream temperature increases. See Chart I [below].

CHART I				
MAXIMUM OPERATING SPEED FOR BELT-DRIVE FANS WITH NAB WHEELS AT VARIOUS TEMPERATURES				
Temp.	Fan size			
	85	105-106	125-126	146
-50°*	4800	4600	4000	3600
70°*	4800	4600	4000	3600
200°*	4800	4600	4000	3600
300°	4800	4600	3980	3570
400°	4800	4600	3960	3490
500°	4800	4600	3940	3410
600°	4800	4600	3860	3310

*Maximum temperature for aluminum wheels is 200°F.
 Note: No derate required for SST wheel construction.

CHART II	
SP AND BHP CORRECTION FACTORS FOR TEMP. (°F.)	
Temp.	Factor
-50°	0.77
-25°	0.82
0°	0.87
20°	0.91
40°	0.94
60°	0.98
70°	1.00
80°	1.02
100°	1.06
120°	1.09
140°	1.13
160°	1.17
180°	1.21
200°	1.25
225°	1.29
250°	1.34
275°	1.39
300°	1.43
325°	1.48
350°	1.53
375°	1.58
400°	1.62
450°	1.72
500°	1.81
550°	1.91
600°	2.00

CHART III	
SP AND BHP CORRECTION FACTORS FOR ALTITUDE [if above sea level]	
Altitude	Factor
0	1.00
500	1.02
1000	1.04
1500	1.06
2000	1.08
2500	1.10
3000	1.12
3500	1.14
4000	1.16
4500	1.18
5000	1.20
5500	1.22
6000	1.25
6500	1.27
7000	1.30
7500	1.32
8000	1.35
8500	1.37
9000	1.40
10000	1.45

NOTE: If correction factor for both temperature and altitude is required, multiply factors from Charts II and III together:
 600°F. and 3000'
 $2.00 \times 1.12 = 2.24$
 [combined factor]

CHART IV						
CGI WHEEL SPECIFICATIONS						
Size	Ni.Al.Br.		Aluminum		304/316 SST	
	Weight	WR ²	Weight	WR ²	Weight	WR ²
85	3.6	0.16	1.3	0.06	3.6	0.18
95	3.8	0.19	1.3	0.07	4.4	0.28
105	5.5	0.38	1.9	0.13	5.5	0.42
125	9.4	1.13	3.3	0.40	7.4	0.82
106	8.2	0.55	2.9	0.20	7.6	0.54
116	8.7	0.66	3.1	0.23	8.7	0.77
126	10.8	1.09	3.8	0.39	9.9	1.05
136	11.4	1.24	4.0	0.44	11.2	1.39
146	11.9	1.42	4.2	0.51	12.5	1.82

DIRECT-DRIVE PERFORMANCE CURVES – 1750 RPM

The numbers within each graph represent brake horsepower values at various points of operation along the curves.

CURVE SELECTION EXAMPLE: Select a fan for 800 CFM at 2" SP. Locate the desired point of operation on the grid in the graphs below, and follow the vertical line up to the nearest performance curve, which is for the Size 146 Compact GI Fan. This fan will deliver 800 CFM at 2.25" SP at approximately 0.72 BHP.

Sizes 85, 95, 105, 125

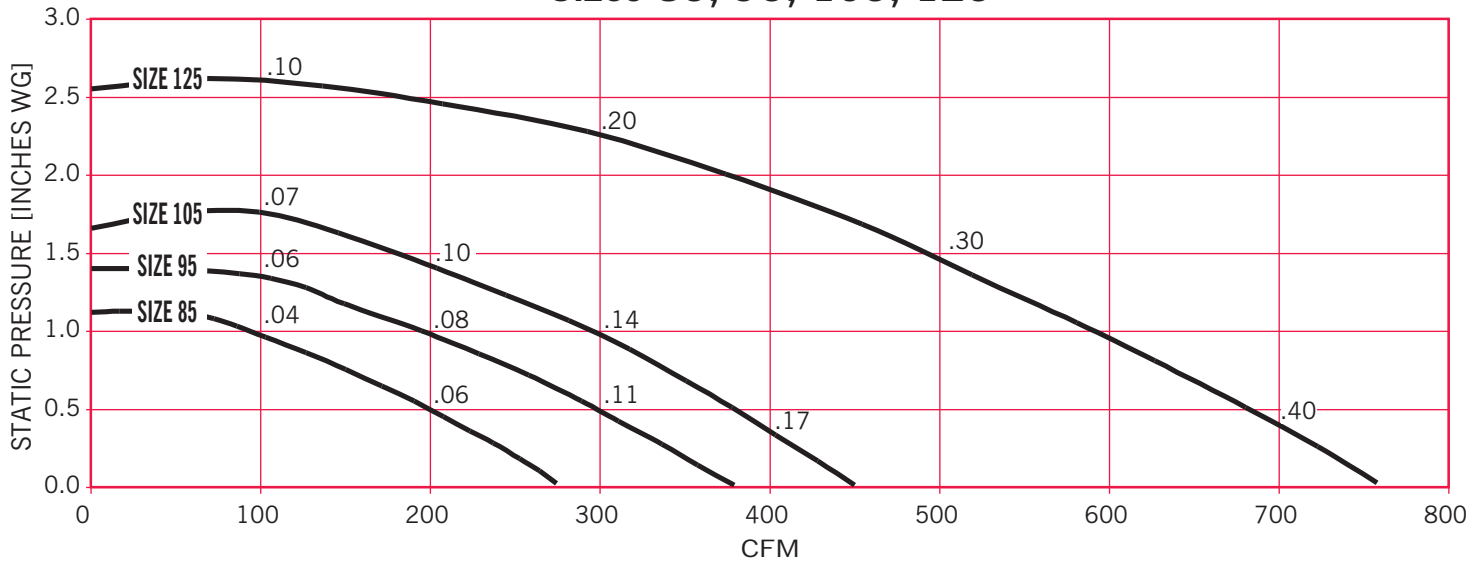

Sizes 106, 116, 126, 136, 146

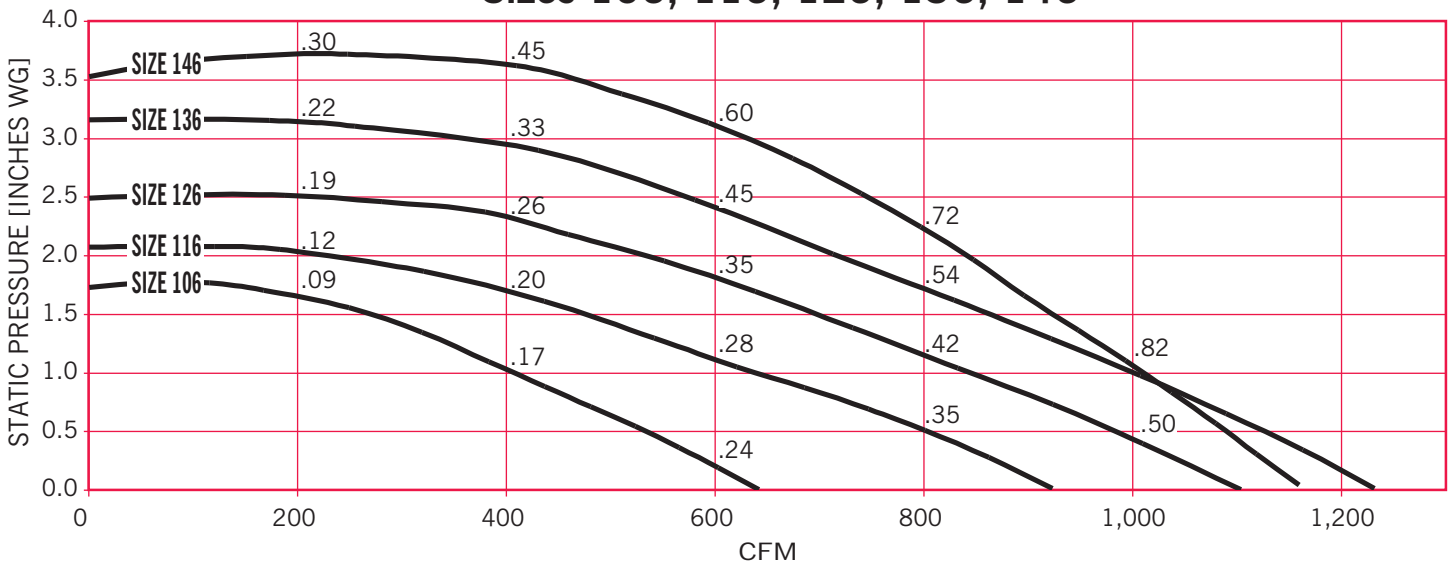

DIRECT-DRIVE CAPACITY TABLE AT 1750 RPM

Size	HP	Inlet dia. OD	Outlet area sq. ft.	1/2"SP			3/4"SP			1"SP			1 1/2"SP			2"SP			2 1/2"SP			3"SP		
				CFM	OV	BHP	CFM	OV	BHP	CFM	OV	BHP	CFM	OV	BHP	CFM	OV	BHP	CFM	OV	BHP	CFM	OV	BHP
85	1/4	5	0.103	199	1932	0.16	151	1466	0.15	95	922	0.14												
95	1/4	6	0.126	298	2365	0.21	250	1984	0.20	194	1540	0.18												
105	1/4	6	0.126	-	-	-	338	2683	0.25	294	2333	0.23	176	1397	0.19									
106	1/2	6	0.203	533	2626	0.31	469	2310	0.29	405	1995	0.27	267	1315	0.22									
125	1/2	7	0.158	677	4285	0.48	632	4000	0.46	585	3703	0.44	484	3063	0.39	365	2310	0.33						
116	1/2	7	0.255	802	3145	0.45	724	2839	0.42	634	2486	0.39	468	1835	0.34	215	843	0.25						
126	3/4	8	0.255	978	3835	0.60	911	3573	0.57	836	3278	0.53	687	2694	0.48	519	2035	0.41						
136	3/4	8	0.293	-	-	-	-	-	-	994	3392	0.74	853	2911	0.67	703	2399	0.59	555	1894	0.52	326	1113	0.39
146	1	8	0.293	1091	3724	0.95	1050	3584	0.93	1006	3433	0.91	915	3123	0.87	828	2826	0.83	727	2481	0.77	605	2065	0.69

Performance certified is for installation type D: Ducted inlet, Ducted outlet. Performance ratings do not include the effects of appurtenances (accessories).

DIRECT-DRIVE PERFORMANCE CURVES – 3500 RPM

The numbers within each graph represent brake horsepower values at various points of operation along the curves.

CURVE SELECTION EXAMPLE: Select a fan for 1250 CFM at 6" SP. Locate the desired point of operation on the grid in the graphs below, and follow the vertical line up to the nearest performance curve, which is for the Size 126 Compact GI Fan. This fan will deliver 1250 CFM at 7.0" SP at approximately 2.9 BHP.

Sizes 85, 95, 105, 125

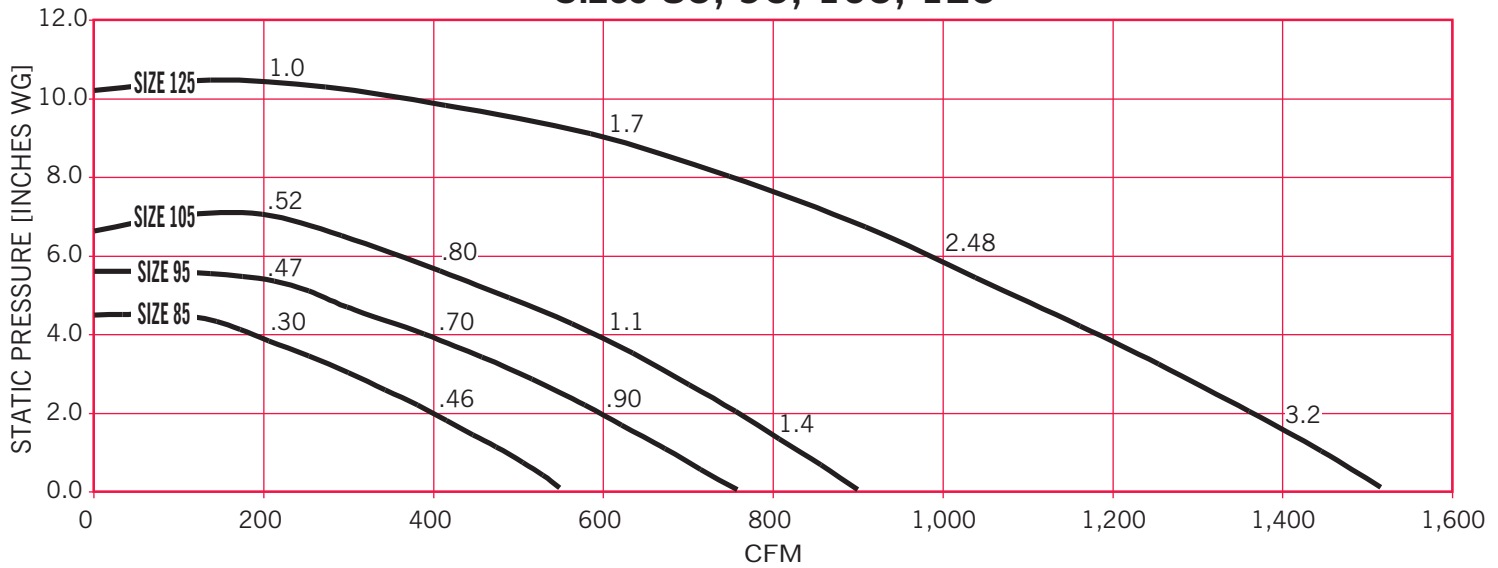

Sizes 106, 116, 126, 136, 146

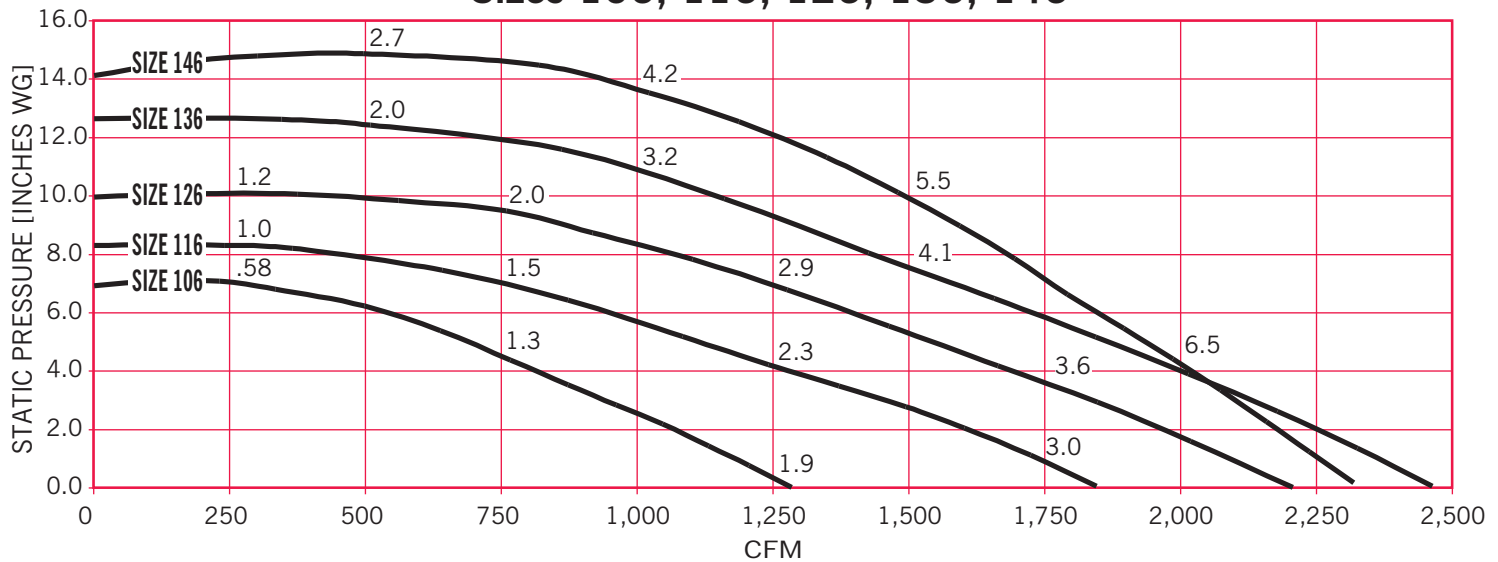

DIRECT-DRIVE CAPACITY TABLE AT 3500 RPM

Size	HP	Inlet dia. OD	Outlet area sq. ft.	2"SP			3"SP			4"SP			5"SP			6"SP			7"SP			8"SP			10"SP		
				CFM	OV	BHP	CFM	OV	BHP	CFM	OV	BHP	CFM	OV	BHP	CFM	OV	BHP	CFM	OV	BHP	CFM	OV	BHP	CFM	OV	BHP
85	¾	5	0.103	399	3874	0.56	302	2932	0.48	-	-	-	-	-	-	-	-	-	-	-	-	-	-	-	-	-	
95	1	6	0.126	595	4722	0.99	500	3968	0.89	388	3079	0.76	262	2079	0.64	-	-	-	-	-	-	-	-	-	-	-	
105	1	6	0.126	-	-	-	-	-	-	-	-	-	476	3778	0.98	353	2802	0.83	-	-	-	-	-	-	-	-	
105	1½	6	0.126	758	6016	1.39	676	5365	1.26	587	465	1.14	476	3778	0.98	353	2802	0.83	-	-	-	-	-	-	-	-	
106	1½	6	0.203	-	-	-	-	-	-	809	3985	1.42	682	3360	1.26	533	2626	1.07	-	-	-	-	-	-	-	-	
106	2	6	0.203	1067	5256	1.78	938	4620	1.59	809	3985	1.42	682	3360	1.26	533	2626	1.07	-	-	-	-	-	-	-	-	
125	2	7	0.158	-	-	-	-	-	-	-	-	-	1068	6759	2.60	968	6127	2.40	861	5449	2.20	730	4620	1.98	-	-	
125	3	7	0.158	-	-	-	1264	8000	2.99	1169	7399	2.81	1068	6759	2.60	968	6127	2.40	861	5449	2.20	730	4620	1.98	-	-	
116	2	7	0.255	-	-	-	-	-	-	-	-	-	-	-	-	-	-	-	738	2894	1.73	430	1686	1.32	-	-	
116	3	7	0.255	1603	6286	2.88	1448	5678	2.65	1268	4973	2.42	1102	4322	2.23	936	3671	2.02	738	2894	1.73	430	1686	1.32	-	-	
126	3	8	0.255	-	-	-	-	-	-	-	-	-	-	-	-	-	-	-	1218	4776	2.90	1038	4071	2.61	-	-	
126	5	8	0.255	1956	7671	4.07	1823	7149	3.84	1672	6557	3.57	1522	5969	3.33	1373	5384	3.13	1218	4776	2.90	1038	4071	2.61	-	-	
136	5	8	0.293	-	-	-	-	-	-	-	-	-	1848	6307	4.93	1705	5819	4.62	1557	5314	4.31	1406	4799	4.01	1111	3792	3.42
146	7½	8	0.293	2183	7451	6.92	2099	7164	6.75	2013	6870	6.59	1924	6567	6.45	1829	6242	6.27	1741	5942	6.11	1656	5652	5.95	1453	4959	5.46

Performance certified is for installation type D: Ducted inlet, Ducted outlet.
Performance ratings do not include the effects of appurtenances (accessories).

BELT-DRIVE CAPACITY TABLES

SIZE 85		Wheel diameter: 8" Inlet: 5" OD Outlet area: .103 sq. ft.																											
CFM	OV	1/8"SP		1/4"SP		1/2"SP		3/4"SP		1"SP		1 1/2"SP		2"SP		2 1/2"SP		3"SP		4"SP		5"SP		6"SP		7"SP			
		RPM	BHP	RPM	BHP	RPM	BHP	RPM	BHP	RPM	BHP	RPM	BHP	RPM	BHP	RPM	BHP	RPM	BHP	RPM	BHP	RPM	BHP	RPM	BHP	RPM	BHP	RPM	BHP
60	583	707	0.10	915	0.11	1218	0.11	1455	0.12	1663	0.13	2025	0.14	2329	0.16	2604	0.19	2852	0.21	3289	0.27	3680	0.33	4034	0.40	4349	0.47		
100	971	877	0.11	1060	0.11	1344	0.12	1576	0.13	1766	0.14	2102	0.16	2382	0.18	2641	0.21	2880	0.23	3310	0.30	3695	0.36	4042	0.44	4355	0.51		
140	1359	1073	0.11	1231	0.12	1494	0.13	1708	0.14	1895	0.16	2224	0.18	2493	0.21	2741	0.24	2959	0.27	3367	0.33	3730	0.40	4069	0.48	4384	0.56		
180	1748	1283	0.13	1428	0.13	1659	0.15	1863	0.16	2041	0.18	2352	0.21	2623	0.24	3092	0.31	3476	0.38	3823	0.46	4150	0.54	4442	0.62	4722	0.70	4999	0.78
220	2136	1508	0.14	1630	0.15	1849	0.17	2029	0.19	2200	0.20	2499	0.24	2756	0.28	2994	0.32	3209	0.36	3603	0.44	3952	0.53	4257	0.62	4546	0.71	4822	0.79
260	2524	1741	0.17	1845	0.18	2046	0.20	2216	0.22	2373	0.24	2658	0.28	2908	0.32	3133	0.37	3338	0.41	3731	0.51	4067	0.60	4386	0.71	4665	0.81	4938	0.90
300	2913	1979	0.20	2069	0.21	2245	0.24	2415	0.26	2561	0.28	2822	0.33	3063	0.38	3286	0.43	3494	0.48	3859	0.58	4197	0.69	4499	0.80	4799	0.92	5099	1.04
340	3301	2221	0.25	2300	0.26	2457	0.28	2612	0.31	2753	0.33	3005	0.39	3234	0.44	3452	0.50	3640	0.55	4009	0.66	4328	0.78	4627	0.90	4927	1.02	5227	1.14
380	3689	2465	0.30	2535	0.31	2677	0.34	2818	0.37	2954	0.40	3199	0.46	3408	0.51	3609	0.57	3807	0.64	4156	0.76	4478	0.89	4765	1.01	5052	1.13	5349	1.25
420	4078	2711	0.37	2773	0.38	2902	0.41	3030	0.44	3157	0.48	3390	0.54	3597	0.60	3789	0.67	3978	0.74	4325	0.87	4632	1.01	4939	1.14	5246	1.27	5553	1.40
460	4466	2957	0.46	3014	0.47	3131	0.50	3249	0.53	3364	0.56	3590	0.63	3794	0.70	3973	0.77	4153	0.85	4482	0.99	4789	1.14	5096	1.27	5403	1.40	5710	1.53
500	4854	3205	0.56	3258	0.57	3364	0.60	3472	0.63	3579	0.67	3794	0.74	3993	0.82	4175	0.90	4342	0.98	4654	1.13	4961	1.27	5268	1.40	5575	1.53	5882	1.66
540	5243	3454	0.67	3502	0.69	3601	0.72	3700	0.75	3799	0.79	3997	0.87	4191	0.95	4368	1.03	4530	1.12	4842	1.27	5149	1.40	5456	1.53	5763	1.66	6070	1.79

SIZE 105		Wheel diameter: 10" Inlet: 6" OD Outlet area: .126 sq. ft.																											
CFM	OV	1/4"SP		1/2"SP		3/4"SP		1"SP		2"SP		3"SP		4"SP		5"SP		6"SP		7"SP		8"SP		9"SP		10"SP			
		RPM	BHP	RPM	BHP	RPM	BHP	RPM	BHP	RPM	BHP	RPM	BHP	RPM	BHP	RPM	BHP	RPM	BHP	RPM	BHP	RPM	BHP	RPM	BHP	RPM	BHP		
80	635	728	0.11	966	0.11	1159	0.12	1323	0.13	1857	0.17	2271	0.21	2636	0.26	2948	0.32	3247	0.38	3501	0.44	3755	0.52	3977	0.59	4201	0.67	4425	0.75
130	1032	832	0.11	1063	0.12	1242	0.13	1399	0.14	1890	0.19	2278	0.24	2628	0.30	2927	0.36	3209	0.43	3475	0.50	3715	0.58	3948	0.66	4166	0.74	4384	0.82
180	1429	963	0.12	1168	0.14	1341	0.15	1494	0.16	1974	0.22	2345	0.28	2668	0.35	2960	0.42	3231	0.50	3480	0.58	3702	0.66	3935	0.75	4157	0.84	4379	0.92
230	1825	1113	0.14	1292	0.15	1453	0.17	1594	0.19	2065	0.26	2429	0.33	2744	0.41	3030	0.50	3279	0.58	3514	0.67	3746	0.76	3952	0.85	4166	0.96	4380	1.04
280	2222	1275	0.16	1436	0.18	1579	0.20	1710	0.22	2160	0.30	2528	0.39	2833	0.48	3104	0.57	3364	0.67	3595	0.77	3806	0.87	4019	0.98	4218	1.09	4428	1.19
330	2619	1446	0.19	1589	0.21	1720	0.24	1841	0.26	2270	0.35	2619	0.45	2931	0.56	3204	0.66	3451	0.77	3678	0.88	3883	0.99	4092	1.11	4281	1.23	4481	1.34
380	3016	1622	0.24	1750	0.26	1873	0.28	1984	0.31	2384	0.41	2727	0.52	3031	0.64	3289	0.75	3544	0.88	3771	1.01	3980	1.13	4178	1.26	4360	1.38	4542	1.50
430	3413	1799	0.29	1919	0.32	2031	0.34	2137	0.37	2506	0.49	2835	0.60	3126	0.73	3394	0.86	3633	1.00	3857	1.13	4068	1.27	4273	1.42	4449	1.55	4641	1.68
480	3810	1979	0.35	2093	0.39	2192	0.42	2290	0.45	2643	0.57	2952	0.70	3233	0.84	3494	0.98	3738	1.13	3951	1.27	4164	1.43	4361	1.58	4546	1.73	4741	1.87
530	4206	2161	0.43	2267	0.47	2362	0.50	2452	0.54	2783	0.67	3075	0.82	3351	0.96	3606	1.11	3838	1.26	4061	1.43	4266	1.59	4455	1.76	4644	1.90	4844	2.04
580	4603	2345	0.53	2443	0.57	2535	0.61	2617	0.64	2937	0.79	3212	0.95	3470	1.10	3714	1.26	3952	1.43	4165	1.60	4361	1.77	4554	1.94	4754	2.08	4954	2.22
630	5000	2532	0.64	2623	0.69	2710	0.73	2790	0.77	3086	0.93	3354	1.09	3599	1.26	3833	1.43	4060	1.61	4273	1.79	4471	1.97	4671	2.15	4871	2.30	5071	2.44
680	5397	2719	0.78	2802	0.82	2885	0.87	2963	0.91	3245	1.09	3503	1.26	3740	1.44	3960	1.62	4179	1.81	4391	2.01	4582	2.19	4782	2.37	4982	2.54	5182	2.68

SIZE 106		Wheel diameter: 10" Inlet: 6" OD Outlet area: .203 sq. ft.																											
CFM	OV	1/4"SP		1/2"SP		3/4"SP		1"SP		2"SP		3"SP		4"SP		5"SP		6"SP		7"SP		8"SP		9"SP		10"SP			
		RPM	BHP	RPM	BHP	RPM	BHP	RPM	BHP	RPM	BHP	RPM	BHP	RPM	BHP	RPM	BHP	RPM	BHP	RPM	BHP	RPM	BHP	RPM	BHP	RPM	BHP		
120	591	727	0.11	971	0.12	1169	0.13	1337	0.14	1859	0.18	2270	0.23	2623	0.29	2939	0.35	3219	0.42	3472	0.49	3727	0.57	3956	0.65	4166	0.73	4376	0.81
200	985	867	0.12	1077	0.13	1247	0.15	1401	0.16	1911	0.22	2306	0.29	2643	0.36	2947	0.43	3226	0.51	3472	0.60	3714	0.68	3928	0.77	4154	0.87	4380	0.96
280	1379	1028	0.14	1221	0.16	1379	0.17	1515	0.19	1976	0.26	2361	0.35	2703	0.44	2993	0.53	3253	0.62	3508	0.72	3743	0.83	3958	0.93	4166	1.03	4384	1.13
360	1773	1196	0.17	1377	0.19	1528	0.21	1659	0.23	2085	0.32	2441	0.42	2767	0.53	3047	0.63	3317	0.75	3563	0.86	3799	0.99	4002	1.10	4212	1.23	4422	1.36
440	2167	1383	0.21	1545	0.23	1687	0.26	1811	0.29	2219	0.40	2559	0.51	2854	0.63	3121	0.75	3382	0.88	3622	1.01	3859	1.15	4063	1.29	4266	1.43	4474	1.57
520	2562	1576	0.26	1717	0.30	1851	0.33	1970	0.36	2368	0.49	2689	0.62	2966	0.75	3228	0.89	3463	1.03	3707	1.18	3921	1.33	4125	1.48	4332	1.65	4540	1.79
600	2956	1774	0.34	1903	0.38	2020	0.41	2136	0.45	2520	0.60	2837	0.75	3104	0.90	3348	1.05	3577	1.20	3801	1.37	3999	1.52	4204	1.70	4396	1.87	4598	2.04
680	3350	1976	0.44	2094	0.48	2201	0.52	2305	0.56	2678	0.73	2980	0.90	3248	1.07	3487	1.24	3703	1.41	3914	1.58	4113	1.76	4307	1.94	4496	2.13	4696	2.27
760	3744	2182	0.56	2288	0.60	2390	0.65	2485	0.70	2842	0.89	3140	1.08	3396	1.27	3632	1.46	3839	1.64	4050	1.84	4241	2.03	4426	2.23	4626	2.42	4826	2.61
840	4138	2389	0.70	2488	0.76	2583	0.81	2670	0.86	3005	1.07	3292	1.28	3551	1.49	3777	1.70	3992	1.91	4185	2.13	4369	2.32	4558	2.54	4758	2.73	4958	2.92
920	4532	2599	0.88	2688	0.94	2776	1.00	2861	1.05	3171	1.28	3454	1.51	3704	1.74	3928	1.97	4134	2.20	4328	2.43	4514	2.66	4709	2.89	4904	3.12	5104	3.35
1000	4926	2810	1.09	2882	1.15	2975	1.22	3055	1.28	3347	1.53	3621	1.78	3862	2.03	4084	2.28	4289	2.53	4485	2.79	4671	3.01	4858	3.24	5054	3.48	5254	3.71
1080	5320	3022	1.34	3098	1.41	3175	1.47	3251	1.54	3526	1.81	3788	2.08	4025	2.35	4245	2.62	4449	2.90	4649	3.15	4849	3.39	5049	3.63	5249	3.87	5449	4.11

SIZE 125		Wheel diameter: 12" Inlet: 7" OD Outlet area													
-----------------	--	--	--	--	--	--	--	--	--	--	--	--	--	--	--

BELT-DRIVE CAPACITY TABLES

SIZE 126		Wheel diameter: 12" Inlet: 8" OD Outlet area: .255 sq. ft.																									
CFM	OV	1/4"SP		1/2"SP		3/4"SP		1"SP		2"SP		3"SP		4"SP		5"SP		6"SP		7"SP		8"SP		9"SP		10"SP	
		RPM	BHP	RPM	BHP	RPM	BHP	RPM	BHP	RPM	BHP	RPM	BHP	RPM	BHP	RPM	BHP	RPM	BHP	RPM	BHP	RPM	BHP	RPM	BHP	RPM	BHP
150	588	587	0.11	792	0.12	967	0.13	1111	0.15	1558	0.22	1903	0.30	2201	0.40	2456	0.50	2698	0.61	2915	0.73	3121	0.85	3304	0.98	3486	1.11
250	980	677	0.12	862	0.14	1010	0.15	1137	0.17	1578	0.25	1920	0.35	2213	0.47	2464	0.59	2693	0.71	2909	0.85	3117	0.99	3307	1.14	3479	1.29
350	1373	789	0.14	954	0.16	1091	0.18	1213	0.20	1604	0.29	1943	0.40	2234	0.53	2482	0.66	2719	0.82	2922	0.96	3126	1.13	3307	1.29	3492	1.47
450	1765	908	0.16	1063	0.19	1191	0.22	1304	0.24	1685	0.36	1983	0.47	2253	0.60	2504	0.75	2735	0.91	2949	1.08	3139	1.25	3328	1.44	3511	1.64
550	2157	1037	0.20	1179	0.23	1300	0.26	1408	0.30	1765	0.43	2065	0.57	2311	0.71	2536	0.86	2764	1.02	2968	1.20	3165	1.39	3348	1.58	3529	1.79
650	2549	1173	0.25	1300	0.28	1419	0.32	1520	0.36	1857	0.52	2137	0.68	2394	0.85	2610	1.01	2817	1.18	3003	1.35	3191	1.54	3368	1.74	3536	1.95
750	2941	1315	0.31	1429	0.35	1536	0.40	1635	0.44	1960	0.62	2230	0.80	2470	0.99	2688	1.18	2893	1.38	3080	1.57	3252	1.77	3412	1.96	3573	2.17
850	3333	1460	0.40	1562	0.44	1660	0.49	1755	0.54	2069	0.74	2328	0.95	2555	1.15	2770	1.37	2974	1.59	3153	1.81	3330	2.03	3486	2.24	3643	2.46
950	3725	1608	0.50	1702	0.55	1791	0.60	1877	0.66	2184	0.88	2431	1.11	2657	1.34	2864	1.58	3051	1.81	3232	2.05	3403	2.30	3568	2.55	3723	2.80
1050	4118	1758	0.63	1845	0.68	1926	0.74	2005	0.80	2302	1.04	2545	1.29	2759	1.55	2960	1.80	3141	2.06	3318	2.32	3485	2.59	3646	2.86	3799	3.14
1150	4510	1909	0.78	1989	0.84	2065	0.91	2138	0.97	2419	1.23	2659	1.50	2869	1.78	3059	2.05	3244	2.34	3409	2.62	3572	2.90	3731	3.20	3882	3.50
1250	4902	2061	0.96	2136	1.03	2208	1.10	2276	1.17	2541	1.45	2773	1.74	2980	2.04	3167	2.34	3342	2.64	3504	2.94	3665	3.25	3812	3.55	3962	3.87
1350	5294	2213	1.17	2284	1.25	2351	1.32	2416	1.39	2663	1.69	2894	2.01	3099	2.33	3277	2.64	3450	2.97	3611	3.30	3762	3.63	3909	3.95		

SIZE 146		Wheel diameter: 14" Inlet: 8" OD Outlet area: .293 sq. ft.																									
CFM	OV	1/2"SP		1"SP		2"SP		3"SP		4"SP		5"SP		6"SP		7"SP		8"SP		9"SP		10"SP		12"SP		14"SP	
		RPM	BHP	RPM	BHP	RPM	BHP	RPM	BHP	RPM	BHP	RPM	BHP	RPM	BHP	RPM	BHP	RPM	BHP	RPM	BHP	RPM	BHP	RPM	BHP	RPM	BHP
180	614	665	0.13	909	0.16	1281	0.23	1571	0.32	1815	0.42	2030	0.53	2232	0.66	2407	0.78	2578	0.92	2735	1.06	2884	1.21	3166	1.53	3426	1.87
300	1024	751	0.15	965	0.19	1301	0.29	1575	0.39	1814	0.51	2026	0.64	2224	0.78	2405	0.93	2565	1.07	2717	1.23	2873	1.41	3143	1.75	3399	2.13
420	1433	874	0.19	1057	0.24	1362	0.36	1617	0.49	1838	0.62	2039	0.77	2227	0.93	2404	1.09	2566	1.26	2719	1.43	2870	1.62	3143	2.01	3393	2.42
540	1843	1018	0.25	1177	0.32	1448	0.45	1686	0.60	1898	0.76	2087	0.93	2263	1.10	2421	1.28	2576	1.47	2737	1.68	2875	1.87	3147	2.30	3390	2.73
660	2253	1168	0.34	1316	0.42	1557	0.58	1774	0.75	1967	0.92	2154	1.11	2318	1.31	2477	1.51	2626	1.72	2769	1.94	2900	2.15	3154	2.60	3400	3.09
780	2662	1324	0.45	1459	0.55	1682	0.74	1880	0.93	2061	1.13	2233	1.33	2397	1.55	2543	1.77	2689	2.00	2820	2.23	2953	2.48	3206	2.99	3425	3.48
900	3072	1486	0.61	1608	0.72	1821	0.94	1999	1.15	2173	1.37	2331	1.61	2478	1.84	2623	2.08	2760	2.32	2893	2.58	3019	2.84	3260	3.39	3487	3.96
1020	3481	1652	0.81	1763	0.92	1965	1.18	2131	1.42	2292	1.67	2440	1.91	2582	2.18	2714	2.44	2845	2.70	2973	2.98	3094	3.26	3327	3.84	3550	4.46
1140	3891	1821	1.05	1922	1.18	2109	1.47	2276	1.75	2418	2.02	2564	2.30	2698	2.57	2822	2.85	2943	3.14	3067	3.44	3185	3.75	3414	4.38		
1260	4300	1992	1.35	2084	1.50	2258	1.80	2419	2.12	2557	2.42	2687	2.72	2820	3.03	2936	3.32	3056	3.64	3171	3.96	3281	4.28	3498	4.95		
1380	4710	2164	1.71	2250	1.88	2413	2.20	2564	2.55	2704	2.89	2826	3.22	2943	3.54	3064	3.88	3177	4.21	3286	4.55	3388	4.88	3597	5.61		
1500	5119	2338	2.13	2418	2.32	2568	2.66	2709	3.03	2846	3.41	2973	3.79	3082	4.14	3187	4.48	3300	4.86	3409	5.23	3511	5.59				
1620	5529	2512	2.63	2587	2.83	2728	3.20	2863	3.60	2993	4.01	3117	4.42	3226	4.80	3327	5.18	3430	5.57								

Performance certified is for installation type D: Ducted inlet, Ducted outlet. Power rating (BHP) does not include transmission losses. Performance ratings do not include the effects of appurtenances (accessories).

MATERIAL SPECIFICATIONS	Housings	Pedestals and drive-side plates	Inlet plates	Bearings [Arr. 1, 9, 9X]
	12 gauge	Sizes 85-106: 12 gauge Sizes 116-146: 10 gauge	14 gauge	Link-Belt P3-U200 Series ball bearings or equal.

FLANGED INLET OPTION

Four 5/16" diameter holes furnished on centerlines.

NOTE-Inlet flange: 10 gauge.

DIMENSIONS
[INCHES]*

Size	ID	BC	OD
85	5	6	7
95	6	7	8
105	6	7	8
106	6	7	8
116	7	8	9
125	7	8	9
126	8	9	10
136	8	9	10
146	8	9	10

*4V flanged inlets differ from dimensions shown.

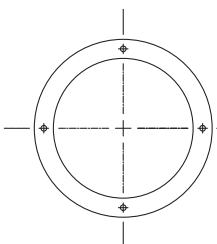

FLANGED OUTLET OPTION

7 gauge flange is mounted flush with outside edge of housing discharge. All sizes have 5/16" diameter corner holes. Sizes 136 and 146 have four additional holes on centerline. Not available on Size 85 Arr. 4 Bottom Horizontal and all Down Blast discharge fans.

DIMENSIONS [INCHES]

Size	A	B	D	M
85	6 5/8	5 5/8	4 5/8	3 5/8
95	7 5/8	5 5/8	5 5/8	3 5/8
105	7 5/8	5 5/8	5 5/8	3 5/8
106	7 5/8	7 5/8	5 5/8	5 5/8
116	9	7 5/8	7	5 5/8
125	9	5 5/8	7	3 5/8
126	9	7 5/8	7	5 5/8
136	10 1/4	7 5/8	8 1/4	5 5/8
146	10 1/4	7 5/8	8 1/4	5 5/8

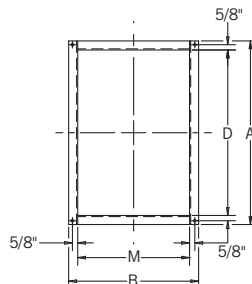

OUTLET DAMPER OPTION

Outlet damper has the effect of extending the fan B dimension per the chart below. Damper outlet dimensions are the same as fan outlet, D, and M. For slip-connection damper only.

Size	Damper extension
85	5 3/8"
95	5 7/8"
105	5 7/8"
106	5 7/8"
116	6 1/2"
125	6 1/2"
126	6 1/2"
136	7 3/4"
146	7 3/4"

DIRECT-DRIVE DIMENSIONS

ARRANGEMENT 4

Size	Motor frame	A
85, 95	48, 56	10½
105	48, 56, 143T, 145T	
106	56, 143T, 145T	
116, 125, 126	56, 143T, 145T	12½
	182T, 184T	13½
136	56, 143T, 145T	12½
	182T, 184T	13½
146	143T, 145T	12½
	182T, 184T	13½

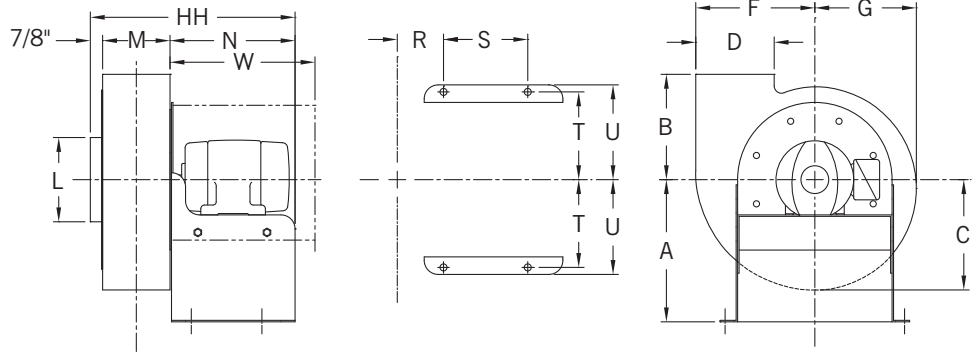

ARRANGEMENT 4V

Size	Motor frame	H*
85, 95	48C, 56C	15¾-18½
105	48C, 56C	15¾-18½
106	56C	20½
	143TC, 145TC	21½
116, 126, 136	56C	20½
	143TC, 145TC	21½
	182TC, 184TC	25½
125	56C,	18½
	143TC, 145TC	19½
	182TC, 184TC	23½
146	143TC, 145TC	21½
	182TC, 184TC	25½

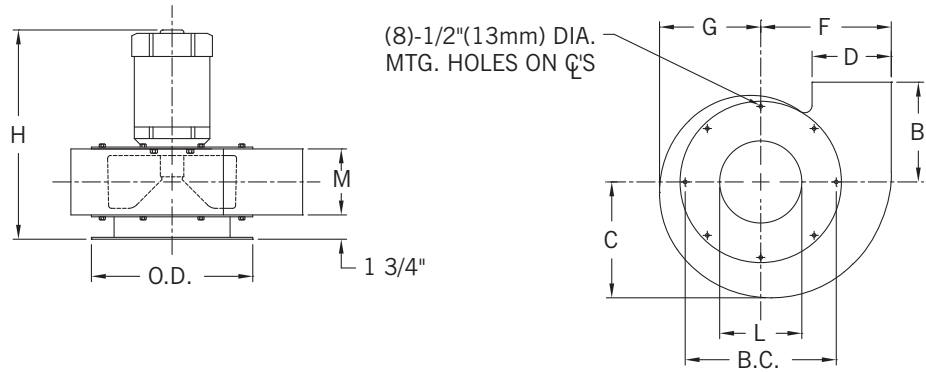

*Range based on motor frame selected using standard duty TEFC motors.

DIMENSIONS [INCHES]

Size	B	C	D	F	G	HH	L	M	N	R	S	T	U	W	a	b	c	d	O.D.	B.C.	Arr. 4 wt. [lbs.]*	Arr. 4V wt. [lbs.]*
85	6	6¾	4⅝	6⅞	5⅞	14⅝	5	3⅝	10⅞	37/16	6	6¼	6¾	14¼	6¼	9⅞	6⅝	5⅝	10	9	35	26
95	7½	7⅞	5⅝	8½	7¼	14⅝	6	3⅝	10⅞	37/16	6	6¼	6¾	14¼	7¾	11¼	8	6¾	12¾	12	39	30
105	7½	7⅞	5⅝	8½	7¼	14⅝	6	3⅝	10⅞	37/16	6	6¼	6¾	14¼	7¾	11¼	8	6¾	12¾	12	40	31
106	7½	7⅞	5⅝	8½	7¼	16⅝	6	5⅝	10⅞	47/16	6	6¼	6¾	14¼	7¾	11¼	8	6¾	12¾	12	45	36
116	8½	10	7	11¼	8¾	17⅝	7	5⅝	11⅞	415/16	7	7¾	8¼	15	9¾	13⅞	10⅝	8⅞	13¾	12⅞	55	42
125	8½	10	7	11¼	8¾	15⅝	7	3⅝	11⅞	315/16	7	7¾	8¼	15	9¾	13⅞	10⅝	8⅞	13¾	12⅞	55	42
126	8½	10	7	11¼	8¾	17⅝	8	5⅝	11⅞	415/16	7	7¾	8¼	15	9¾	13⅞	10⅝	8⅞	13¾	12⅞	60	47
136	10½	11⅞	8¼	12	10¼	17⅝	8	5⅝	11⅞	415/16	7	7¾	8¼	15	10¾	16	11½	9¾	18	16½	70	59
146	10½	11⅞	8¼	12	10¼	17⅝	8	5⅝	11⅞	415/16	7	7¾	8¼	15	10¾	16	11½	9¾	18	16½	70	59

L is OD of collar. M and D are outside dimensions. W pertains to optional weather cover. *Bare fan weight, less motors. Arr. 4 base holes and Arr. 4V mounting holes = ½"

Tolerance: ± 1/8"

FAN DISCHARGES – VIEWED FROM DRIVE SIDE

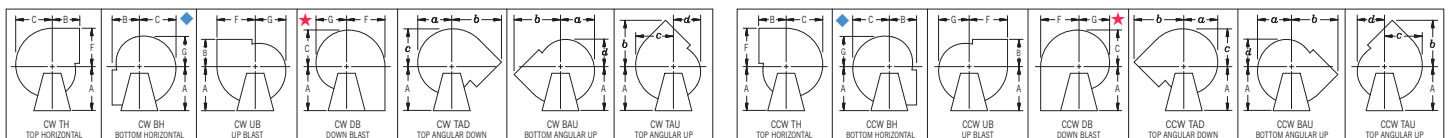

Clockwise—angular discharges at 45°

Counterclockwise—angular discharges at 45°

◆ On Size 146 in Bottom Horizontal discharge with optional flanged outlet, the flange extends below the Arrangement 1 or 9 baseline.

★ Down Blast discharge is not available in Arrangement 9X.

BELT-DRIVE DIMENSIONS

ARRANGEMENT 1

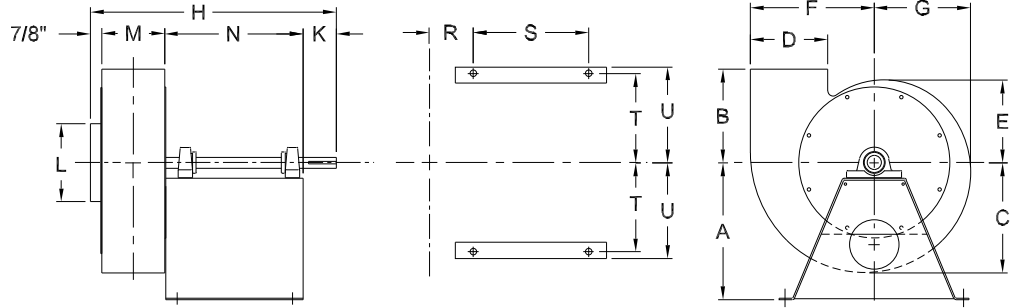

ARRANGEMENT 9

MINIMUM-MAXIMUM V-BELT DRIVE CENTERS [INCHES]

Size	Frame	Min.	Max.
85, 105, 106	48	8½	10¼
	56	8⅞	10⅝
125, 126, 146	48	9⅝	11¾
	56/143/145	10	12⅛

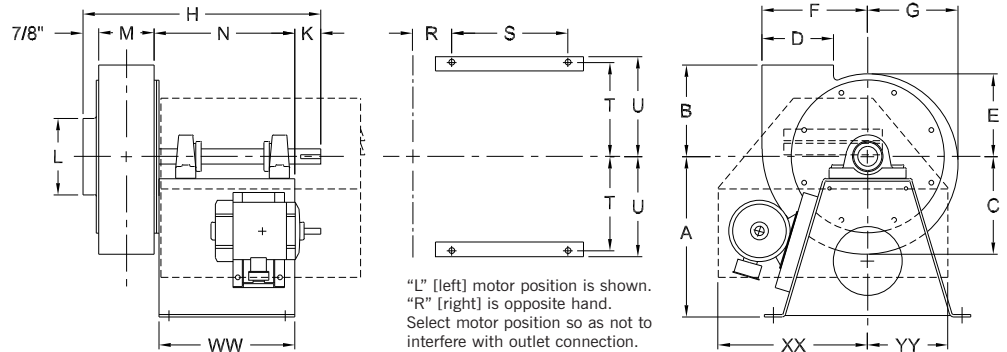

ARRANGEMENT 9X

MINIMUM-MAXIMUM V-BELT DRIVE CENTERS [INCHES]

Size	Frame	Min.	Max.
85, 105, 106	48	14	17¼
	56/143/145	14½	16⅝
125, 126, 146	56/143/145	16⅞	18⅝
	182/184	15½	18

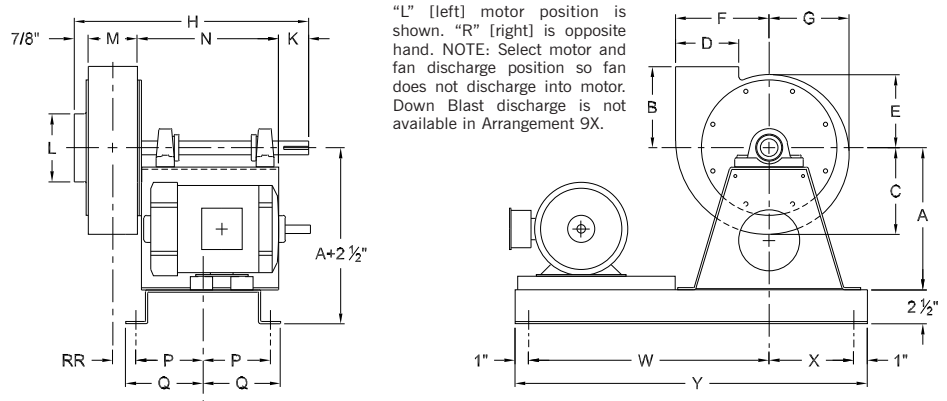

DIMENSIONS [INCHES]

Size	A	B	C	D	E	F	G	H	K	L	M	N	P	Q	R	RR	S	T	U	W
85	10½	6	6¾	4⅝	5¾	6⅞	5⅞	17	2¼	5	3⅝	10¼	5½	5⅞	3¾	1¼	6	6¼	6¾	17¾
105	10½	7½	7⅞	5⅝	6⅝	8½	7¼	17	2¼	6	3⅝	10¼	5½	5⅞	3¾	1¼	6	6¼	6¾	17¾
106	10½	7½	7⅞	5⅝	6⅝	8½	7¼	19	2¼	6	5⅝	10¼	5½	5⅞	4¾	2¼	6	6¼	6¾	17¾
125	12½	8½	10	7	7½	11¼	8¾	20⅞	3	7	3⅝	12⅝	7½	7⅞	3	1½	10½	8⅞	8⅝	20⅞
126	12½	8½	10	7	7½	11¼	8¾	22⅞	3	8	5⅝	12⅝	7½	7⅞	4	2½	10½	8⅞	8⅝	20⅞
146	12½	10½	11⅞	8¼	9¾	12	10¼	22⅞	3	8	5⅝	12⅝	7½	7⅞	4	2½	10½	8⅞	8⅝	20⅞

Size	WW	X	XX	Y	YY	a	b	c	d	Max. motor length ★				Shaft dia.	Keyway	Base holes	Bare fan weights [lbs.] †		
										Arr. 9	Arr. 9X	Arr. 9	Arr. 9X				Arr. 1	Arr. 9	Arr. 9X
85	14⅝	6¼	13½	26	5½	6¼	9⅞	6⅝	5⅝	9½	127	56	145T	1	¼ x ⅛	½	40	40	55
105	14⅝	6¼	13½	26	5½	7¾	11¼	8	6¾	9½	127	56	145T	1	¼ x ⅛	½	45	45	60
106	14⅝	6¼	13½	26	5½	7¾	11¼	8	6¾	9½	127	56	145T	1	¼ x ⅛	½	50	50	65
125	17⅝	8⅞	14⅝	31	7¾	9¾	13⅞	10⅝	8⅞	11¾	127	145T	184T	1	¼ x ⅛	½	60	60	85
126	17⅝	8⅞	14⅝	31	7¾	9¾	13⅞	10⅝	8⅞	11¾	127	145T	184T	1	¼ x ⅛	½	65	65	90
146	17⅝	8⅞	14⅝	31	7¾	10¾	16	11½	9¾	11¾	127	145T	184T	1	¼ x ⅛	½	80	80	105

L is OD of collar. M and D are outside dimensions. ★ Maximum motor length is NEMA C - NW dimension. † Less motors and V-belt drives.

COMPLETE SELECTION OF AIR-MOVING EQUIPMENT

The New York Blower Company offers thousands of different types, models, and sizes of air-moving equipment. Contact your nyb representative for assistance in identifying the best fan for your application.

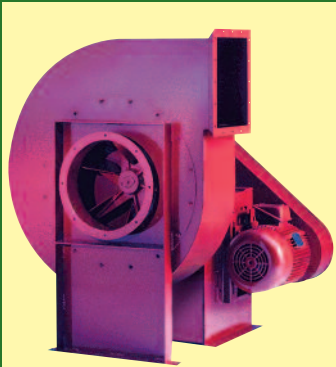

DUST/MATERIAL HANDLING

Wide range of duty available with unique fan lines capable of handling light dust to heavy material. Typical applications include dust-collection and high-pressure process along with material-conveying.



AIR-HANDLING [CENTRIFUGAL]

Designed for clean to moderately dirty gas streams. Commercial and industrial HVAC, process cooling, light material-conveying, heat removal, and dryer exhaust are just a few of the numerous sample applications



AIR-HANDLING [AXIAL]

For the ideal handling of clean to moderately dirty airstreams. Commercial and industrial HVAC, drying and cooling systems, fume extraction, and process-heat removal are typical applications.



FIBERGLASS REINFORCED PLASTIC [FRP]

Choice of performance and duty for corrosive gas streams. Applications include chemical process, wastewater treatment, laboratory hood exhaust, and tank aeration.

CUSTOM PRODUCTS

Designed for unique applications. Variety of configurations, temperatures, flows, and pressures. Wide range of modifications and accessories are available to meet the most demanding specifications.

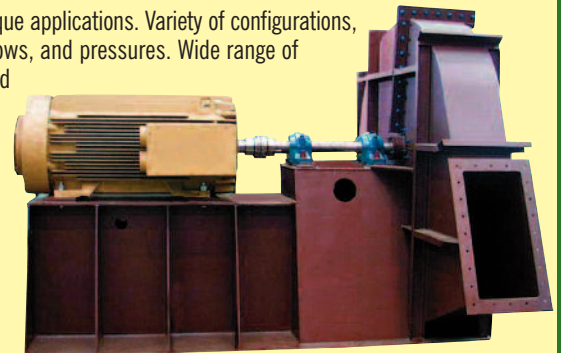

Leading the industry forward since 1889



ROOF VENTILATORS

Including both hooded and upblast ventilators, propeller fans, and centrifugal roof exhausters. These units are ideal for industrial, commercial, and institutional applications.



HEATING PRODUCTS

Industrial-duty steam unit heaters with steam heating coils are available for facility heating and process-heat transfer.

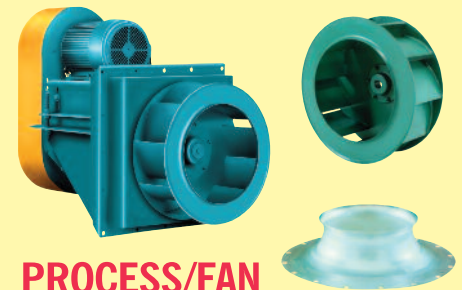

PROCESS/FAN COMPONENTS

Plug fans, plenum fans, wheels, inlet cones, and housings for a wide variety of OEM applications. Process/fan components are used in air-handling units, ovens, dryers, freezer tunnels, and filtration systems.